

# Project Specification and Project Plan

**EML 4551C – Senior Design – Fall 2011 Deliverable**

Team # 15

**Shannon Berger, James Fadool, Seth Murphy, McKenzie Reed, Charles Sistare and Devin Walden**

*Department of Mechanical Engineering and Department of Electrical and Computer Engineering, FAMU-FSU College of Engineering, Tallahassee, FL*

*Project Sponsor*  
Kennedy Space Center NASA



*Project Advisers:*

**Dr. Jonathan Clark, PhD**  
*Department of Mechanical Engineering*

**Dr. Michael Frank, PhD**  
*Department of Electrical and Computer Engineering*

*Reviewed by Advisers:*

*Michael Frank (M. Frank)*

*Jonathan Clark*

---

## **Table of Contents**

Introduction.....	3
Project Specification.....	4
Customer Needs.....	4
Desired Outcome.....	4
Functional Diagram.....	5
Budget.....	6
Gantt Chart.....	7
Team Deliverables.....	8

## **Introduction**

The goal of the 2011-2012 NASA Lunabotics competition is to further advance lunar and planetary robotics. The competition will simulate lunar excavation with either a wireless remote access or autonomous system. Each team will build a robot capable of excavating regolith (lunar soil) and depositing it into an elevated bin at the other end of the competition area. Our system will be capable of handling the difficulties of traversing terrain similar the environment found on the moon.

# Project Specification

## Customer Needs

- Hexcavator needs to weigh less than 80kg.
- Entire system must be self-powered.
- Robot needs to be capable of locomotion.
  - Customer goal is to have a walking is November 30<sup>th</sup>, 2011.
- Robot needs to be capable of excavation and transporting regolith.
- Moving parts that require protection from the regolith material must be regolith-resistant.
- Hexcavator must stay in defined competition arena.
- Robot must be able to traverse simulated lunar terrain, including obstacles.
- Robot needs to excavate at least 10kg of regolith material in ten minutes.
- Robot must be able to release regolith material into LunaBin which stands 0.5m from regolith surface.
- Hexcavator must be free of physical contact from the team during competition timed run.
- Wireless communication must be set up to operate robot.
  - While not needed, a fully autonomous Hexcavator is preferred.
- Amount of energy used needs to be as little as possible.
- Must be free of any design features that would not operate in a lunar atmosphere (i.e. suction or water cooling).
- Hexcavator needs red emergency stop button that can easily be accessed by the NASA judges in the event of a problem or malfunction.

## Desired Outcome

The desired outcome for this project is to be able to traverse the simulated moon environment while overcoming obstacles with our Hexcavator Lunabot. Upon reaching the opposite end of the course, the robot will excavate the regolith, store it onboard the robot, and go back across the simulated moon environment. Once the robot reaches the starting area of the course it will deposit the regolith into the repository; at least 10kg of regolith needs to be deposited. During this project we will design a hexapedal robot, named Hexcavator, capable of performing all of the aforementioned tasks while maintaining locomotion.

The competition for this robot is in May 2012, however the first self imposed due date is to have the robot walking by November 30<sup>th</sup>. Once the robot is walking, we will design and implement an excavation system. After all the systems are integrated and fully functional, we will also develop a wireless communications system as well as we will redesign the frame so that we can make the robot as light as possible. After the robot has been completed, a body will also be designed so that the robot will be dust resistant, lightweight and still sturdy.

## Functional Diagram

Below in Figure 1, is the functional diagram which will be followed to build the robot. It shows how the components of the Hexcavator will work in conjunction with each other. Since this is a hexapedal robot this process will be iterated in each leg. There is a mechanical connection from the legs to the gear box, the gearbox to the motor, and the motor to the encoder. The encoder then sends data to the decoder, which then sends data to the Micro-Controller, which in turn sends data to the excavation system. Batteries send electrical power to the motor driver, micro controller, communication system and excavation system. The excavation system mechanically acquires regolith. The communication system feeds data back to the Micro-Controller and to the operator. The motor driver sends electrical power to the motor.

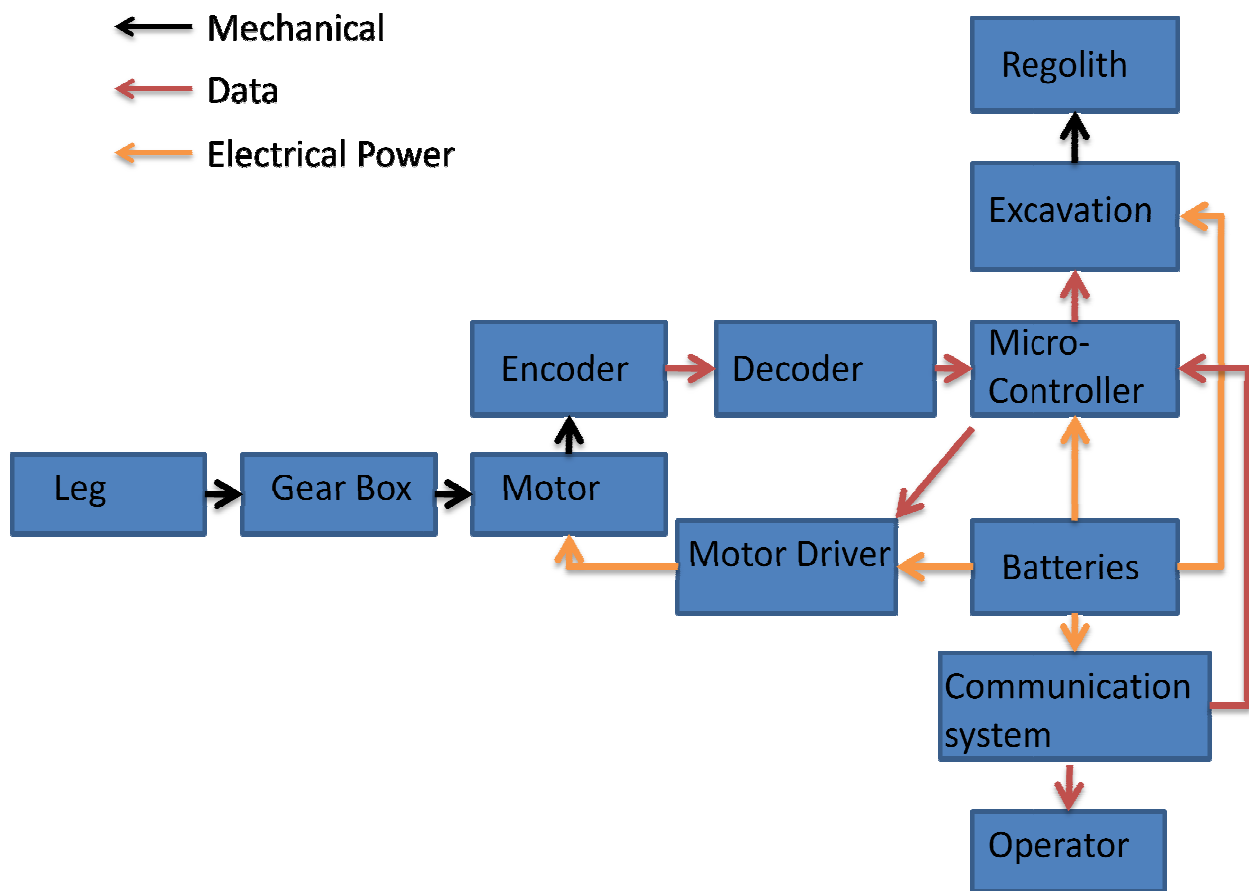

**Figure 1: Function diagram of the Hexcavator. This is a hexapedal robot so this process will be iterated in each leg.**

## Budget

The approximate budget of our project is \$11,000. This is supplied by National Space Grant, Florida Space Grant, and the Mechanical Engineering Department at the FAMU-FSU College of Engineering. Many of the materials needed for this project have already been purchased by the team that competed in last year's competition. The additional costs are indicated in the 'Additional' column of our proposed budget, provided below in Table 1.

Category	Description	QTY	Cost	Total	Will be Purchased	Additional
<b>Motor</b>	Drive Motors	9	\$600.00	\$5,400.00	0	\$0.00
	Gear boxes	6	\$1,200.00	\$7,200.00	0	\$0.00
	Back Up Gear boxes	2	\$1,200.00	\$2,400.00	1	\$2,400.00
	Excavation Motor	2	\$300.00	\$600.00	1	\$600.00
<b>Batteries</b>	36 Volt LiPo Battery	4	\$600.00	\$2,400.00	0	\$0.00
	12 Volt LiPo Battery	2	\$100.00	\$200.00	0	\$0.00
<b>Electronics</b>	Microcontroller	1	\$600.00	\$600.00	1	\$600.00
	Sensors (Infrared, Temperature, etc.)	1	\$500.00	\$500.00	1	\$500.00
	High Current Motor Drivers	6	\$200.00	\$1,200.00	1	\$1,200.00
	Wifi Transceiver	2	\$80.00	\$160.00	1	\$160.00
	Voltage Regulators	3	\$25.00	\$75.00	1	\$75.00
	Miscellaneous Wires and Connectors	1	\$200.00	\$200.00	1	\$200.00
<b>Actuation</b>	Slide Rails	2	\$200.00	\$400.00	1	\$400.00
<b>Tools</b>	Water Jet Nozzle Replacements	2	\$300.00	\$600.00	1	\$600.00
	Metric Taps	8	\$30.00	\$240.00	1	\$240.00
	End mills	10	\$30.00	\$300.00	1	\$300.00
	Jobber Bits	3	\$12.00	\$36.00	1	\$36.00
<b>Raw Materials</b>	Aluminum Plate	1	\$700.00	\$700.00	1	\$700.00
	ABS Plastic	1	\$200.00	\$200.00	1	\$200.00
	Aluminum Square Tubing	3	\$25.00	\$75.00	1	\$75.00
	Carbon Fiber	1	\$500.00	\$500.00	1	\$500.00
				<b>Totals</b>	<b>\$23,986.00</b>	<b>\$8,786.00</b>

Table 1: Above is our proposed budget for the 2011-2012 NASA Lunabotics project to build the Hexcavator.

The total cost of \$8,786.00 does not include the cost of travel and accommodations for the competition at the Kennedy Space Center. It also does not take into account any donations that may be provided by suppliers.

## Gantt Chart

In Figure 2 the Gantt chart which indicates our preliminary time line for building the robotic system. The weeks indicated on the Gantt chart are begin with the dates indicated in Table 2. The final two weeks in December are not included due to the holidays.

Week 1	10/3/2011	Week 18	2/13/2012
Week 2	10/10/2011	Week 19	2/20/2012
Week 3	10/17/2011	Week 20	2/27/2012
Week 4	10/24/2011	Week 21	3/5/2012
Week 5	10/31/2011	Week 22	3/12/2012
Week 6	11/7/2011	Week 23	3/19/2012
Week 7	11/14/2011	Week 24	3/26/2012
Week 8	11/21/2011	Week 25	4/2/2012
Week 9	11/28/2011	Week 26	4/9/2012
Week 10	12/5/2011	Week 27	4/16/2012
Week 11	12/12/2011	Week 28	4/23/2012
Week 12	1/2/2012	Week 29	4/30/2012
Week 13	1/9/2012	Week 30	5/7/2012
Week 14	1/16/2012	Week 31	5/14/2012
Week 15	1/23/2012	Week 32	5/21/2012
Week 16	1/30/2012	Week 33	5/28/2012
Week 17	2/6/2012		

Table 2: Shows what days the weeks indicated in the chart begin with.

If time allows and full testing of the entire Hexcavator system has been completed and is a success, the group will be looking into making the robot completely autonomous. For this to be done, many more sensors would be needed. The rules of the competition state that beacons are allowed to be used in the containment area. Theoretically, infrared beacons would be used to get the Hexcavator to arrive at the excavation zone and to the LunaBin without any control from the group whatsoever. Extensive programming would need to be done to achieve these feats due to the fact that sensory reading is limited to visuals only. This is required due to the Hexcavator competition criteria which states that systems can only be used that would actually function in the lunar atmosphere. Also, further testing would need to be done to make sure they would be reliable and useful additions to the complete system. This would be done in the final months of testing the Hexcavator.

## Team Deliverables

The team has come up with their own internal goals, which can be seen in the gray rows of the Gantt Chart. They are further explained below:

### **Research**

Intended Completion Date: Week 5

The team has performed an in-depth analysis of the former year's robot to determine which components can be utilized again for this year (discussed above in the budgeting section). Currently the team is researching locomotion schemes, controls and different methods of excavation. The team has found potential controllers and motor controllers, but will be meeting with a local technical expert, Dr. Camillo Ordonez, to determine if the selected ones will be suitable.

### **Prototype 1a: Walking Platform**

Intended Completion Date: Week 12

By the end of week 12, the group would like to have a functional walking hexapedal platform. Achieving this will entail acquisition of needed electrical components, installation, programming and testing of the drive system.

Even though the long term goal is for the robot to be controlled via WiFi, an umbilical tether will be used initially for simplicity. Once the robot is mobile, it will be tested indoors. The next step is to test Hexcavator in an outdoor sand pit. This will test Hexcavator's capabilities on non-consistent surface. After testing Hexcavator's ability to go forwards and backwards, the robot will need to be programmed to make turns within the confinements of the competition arena.

### **Initial Prototype of Excavation**

Intended Completion Date: Week 12.

The production of the excavation system will be a multistep process involving design, integration, and improvement. Initially, the group will create designs to implement an excavation apparatus that could work with the existing Hexcavator frame. Upon choosing the most viable of the designs, initial prototyping will be done using a laser cutter to cut inexpensive plastic materials to see if selected design is feasible. Using this prototype, excavation experiments will be preformed. This will most likely be done in sand, however, if a better regolith simulat is available, it will be used instead. The frame of the current robot will then be analyzed to see if an iteration of the excavation prototype can be added. If the current frame is deemed unable to adapt to the excavation system, a new frame will be designed. By the completion of week 12, the current Hexcavator frame will either be deemed successful or will be discarded and redesign of the frame will have begun.



## **Prototype 1b: Excavation Design**

Intended Completion Date: Week 17

The most important step of designing the excavation system is to test the ability to extract soil from the ground. The design will initially be tested on a Hexcavator mockup instead of the actual robot. This will minimize the amount of problems that need to be dealt with to ensure that the excavation system begins functioning correctly. The system will first be tested in soft ground to determine mining capabilities and to look for any shortcomings. If it works, the next step is to test if the excavator works on soil from a more compacted ground. The key here is the strength of the excavation system and its ability to dig into the compacted ground. The final step is to find an efficient way to release the soil into a bin. This will depend on the control method of the excavation system. This final test is critical for the excavation system and for the ability to do well in the competition. By the conclusion of week 17, the excavation system will be extracting both soft and compacted soil from the ground and will be depositing it into a test bin, although it may not be flawless.

## **Prototype 2: Wireless Walking Robot with Excavation**

Intended Completion Date: Week 22

The Hexcavator will have considerably more mass above the top of the robot when the excavation system is attached. Hexcavator will need to undergo testing and control refinement to maintain its locomotion capabilities. The system will also need to be tested to see if it is still capable of picking up soil. Additional testing will be performed to see how Hexcavator's locomotion is impacted when the excavation system is carrying the regolith. Depositing the regolith simulants will also need to be tested so that the maximum amount will be deposited. Navigating over obstacles will also need to be tested with the additional weight of the excavation system, with and without regolith. During these testing phases a wireless communications system will be implemented so that the robot will not need its umbilical tether.

## **Prototype 3: Walking Robot in Rough Terrain**

Intended Completion Date: Week 29

The final steps that will be tested and practiced on the Hexcavator system will be making sure that the complete system is working correctly and efficiently. This will include navigating all obstacles, such as rocks, craters, and rough terrain. Also, the entire system will need to be capable of collecting soil and traversing a practice course to deposit into a practice bin. The excavation system at this point should be collecting the simulated regolith without hindering locomotion. It will then traverse the practice course to successfully deposit said substitute material into a practice bin that will simulate the LunaBin that will be used during competition. At the end of this deliverable, the team will participate in NASA's competition at Kennedy Space Center on May 23.

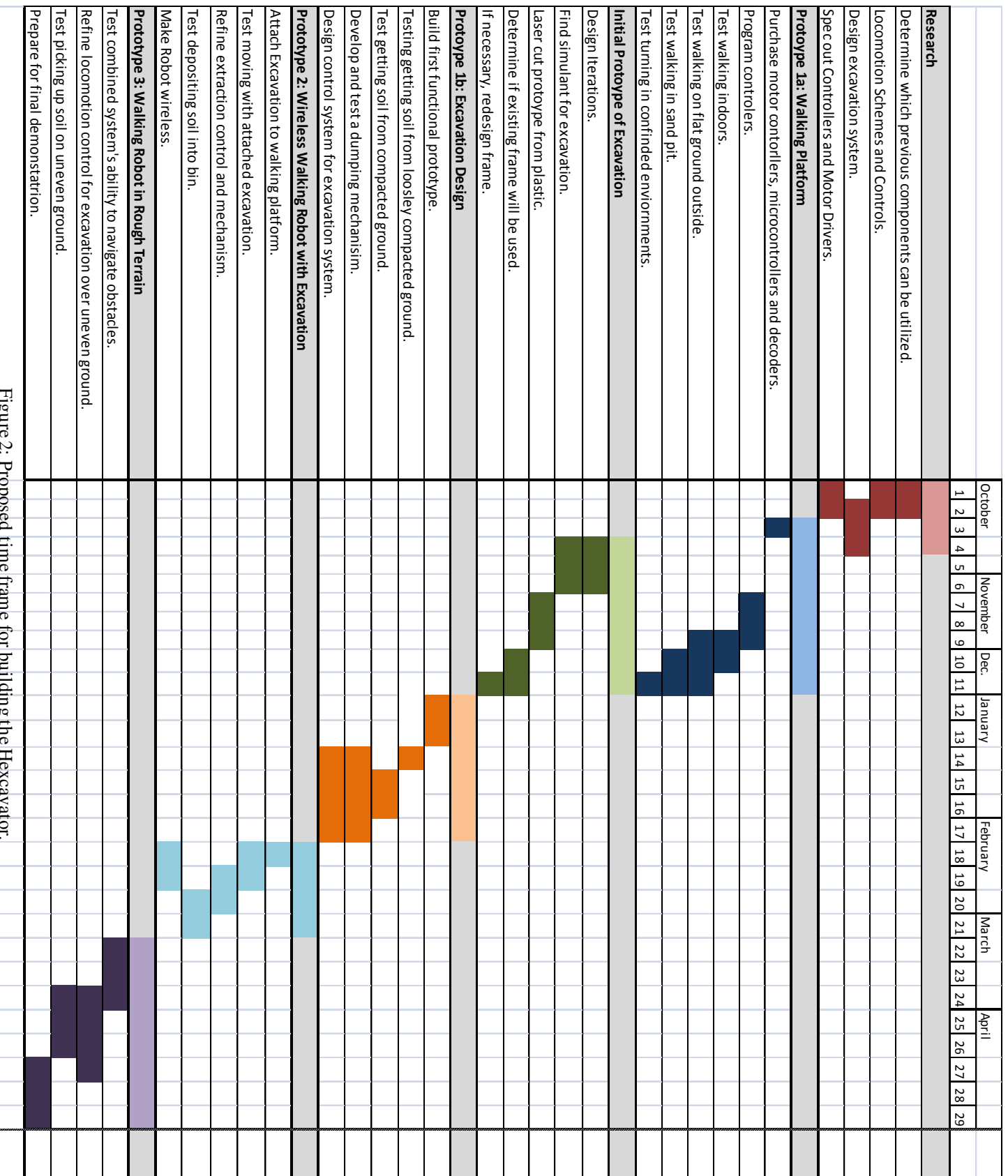

Figure 2. Proposed time frame for building the Hexcavator.

